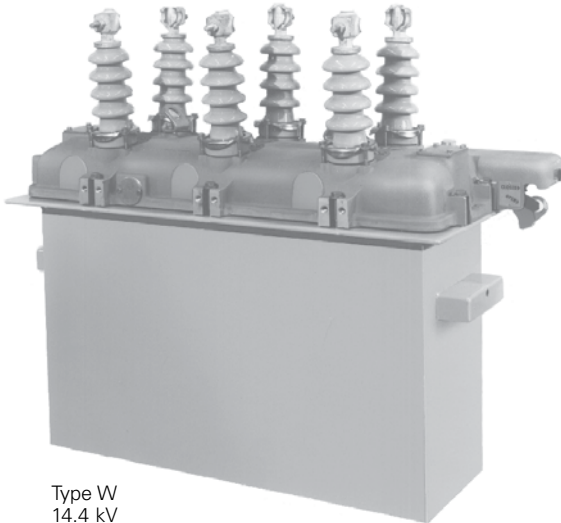


# Types W, WV27, WV38X, VW, VVV27, and VVV38X, three-phase hydraulically controlled reclosers



Type W  
14.4 kV



Type VW  
15.5 kV

## General

Eaton provides reliable, economical overcurrent protection for distribution circuits with its Cooper Power™ series W-group three-phase automatic, circuit reclosers rated through 38 kV. Compact and self-contained in operations, these reclosers can be easily installed on poles and in substations. Employing the service-proven hydraulic control, the W-group reclosers can be readily coordinated with circuit breakers, sectionalizers, fuses, and other reclosers on the distribution system.

Eaton's reclosers in a distribution system protection scheme offer significant user advantages. Their broad application capabilities permit the user to select exactly the right recloser for the protection required. When needed, application expertise, backed by worldwide recloser application experience, is readily available. Knowledgeable design capability, based on over 60 solid years of recloser manufacturing experience, is the backbone of our dependable reclosers. Progressive development programs using the latest technologies have resulted in the modern, efficient reclosers from Eaton.

W-group reclosers, like all reclosers from Eaton, are designed and built in accordance with ANSI® C37.60.

Six distinct types, W, WV27, WV38X, VW, VVV27, and VVV38X, within the W-group offer a broad range of voltage, continuous current, and interrupting ratings. Accessories permit tailoring a recloser to specific application requirements. Mounting equipment for both pole and substation facilitates installing a recloser precisely where system requirements demand its protection.

## Basic ratings

W and VW reclosers protect systems rated 2.4 through 14.4 kV; WV27 and VVV27 reclosers protect systems rated through 24.9 kV; and WV38X and VVV38X reclosers protect systems rated through 34.5 kV. Table 1 summarizes the ratings of the W-group reclosers. For basic ratings and application information for all reclosers from Eaton, see Catalog Section CA280002EN.

**EATON**

*Powering Business Worldwide*

## Basic characteristics

W-group reclosers are hydraulically controlled protective devices in which tripping is initiated by a series trip coil that releases the stored-energy trip mechanism when an overcurrent occurs. Current-carrying and interrupting capacities depend on the rating of the recloser series trip coil. Minimum-trip current is 200% of the coil rating, except X coil ratings which initiate tripping at approximately 140%.

A closing solenoid supplies the energy for contact closing and also stores energy in the trip mechanism. High-voltage closing solenoids are connected to the system on the source side of the recloser. Solenoid phase-to-phase voltage rating is based on the system operating voltage. Low-voltage closing solenoids can be used if auxiliary voltage is supplied to the recloser.

Dual time-current characteristics permit coordinating W-group reclosers with other protective devices on a distribution system. Fast-curve trip operations are followed by trip operations on a delayed curve. A choice of four delayed characteristics allows flexibility in system coordination. Ground tripping is available as an accessory. A variety of operating, indicating, and service accessories extends a W-group recloser's normal flexibility even further.

## Oil interruption

W, WV27, and WV38X reclosers use oil as the arc-interrupting medium. Movable bridge-type contacts provide two breaks in series on each phase. Separate self-generating interrupter chambers at each of the two breaks effectively interrupt all currents from minimum load to rated maximum fault.

## Ratings and specifications

**Table 1. Basic Ratings**

Nominal Voltage (kV)	Maximum Continuous Current (A)	Maximum Interrupting Rating at Nominal Voltage (sym A)	Interrupting Medium	Recloser Type
14.4	560	10000	Oil	W
14.4	560	12000	Vacuum	VW
24.9	560	8000	Oil	WV27
24.9	560	12000	Vacuum	VVW27
34.5	560	8000	Oil	WV38X
34.5	560	12000	Vacuum	VVW38X

**Table 2. Electrical Ratings**

Description	Types W and VW	Type WV27	Type VVW27	Type VVW38X	Type WV38X
Nominal system voltage (kV)	2.4-14.4	24.9	24.9	24.9-34.5	24.9-34.5
Maximum rated voltage (kV)	15.5	27	27	38	38
Rated impulse withstand voltage (BIL) (kV crest)	110	150	125*	150	170
60 Hz withstand voltage (kV rms)					
Dry, one minute	50	60	60	70	70
Wet, ten seconds	45	50	50	60	60
Rated maximum continuous current (A)	560	560	560	560	560
Reclosing time (seconds)	2	2	2	2	2
Bushing creepage distance (in.)	13	26-1/2	26-1/2	26-1/2	26-1/2

\* Can be increased to 150 kV BIL with an accessory.

**Table 3. Definite Purpose Capacitor Switching Ratings**

Description	VW	VVW27	VVW38X*
Isolated Bank (A rms)	400	400	250
Parallel Bank			
Current (A)	400	400	250
Peak current (kA)	20	20	20
Transient inrush frequency (Hz)	4240	4240	6800

\* Applies to solidly grounded bank applications.

## Vacuum interruption

VW, VVW27, and VVW38X reclosers use vacuum as the arc-interrupting medium. Vacuum interruption not only means long contact life, it also offers considerably longer duty cycles than oil interruption. A single break on each phase is accomplished by separating contacts inside the vacuum interrupter. All arcing is contained within the vacuum envelope. Low-energy arc interruption in a vacuum results in far less shock and demonstration than interruption in oil, thus extending the vacuum recloser mechanism life. Because interruption within the vacuum envelope does not add contaminants to the insulating oil, recloser maintenance is minimized and intervals between oil changes can generally be extended.

## Surge protection

Best operating results are achieved if reclosers are protected with surge arresters. On line applications, arrester protection is recommended on both sides of the recloser. (If protection is on one side only, it should be on the source-side.) In substations, arresters should be on the load-side. Eaton's Cooper Power series distribution-class arresters provide excellent protection and are available with mounting brackets to fit reclosers from Eaton; see *Service Information MN280024EN, KA126H3 and KA847W Surge Arrester Mounting Brackets Assembly and Installation Instructions*.

**Table 4. Interrupting Ratings**

Trip Coil Rating Continuous A	Minimum Trip A	W						
		@ 4.8 kV	@ 14.4 kV	VW 2.4–14.4 kV	WV27 @ 24.9 kV	VVV27 @ 24.9 kV	WV38X 24.9–34.5 kV	VVV38X 24.9–34.5 kV
5	10	300	300	300	300	300	300	300
10	20	600	600	600	600	600	600	600
15	30	900	900	900	900	900	900	900
25	50	1500	1500	1500	1500	1500	1500	1500
35	70	2100	2100	2100	2100	2100	2100	2100
50	100	3000	3000	3000	3000	3000	3000	3000
70	140	4200	4200	4200	4200	4200	4200	4200
100	200	6000	6000	6000	6000	6000	6000	6000
140	280	8400	8400	8400	8000	8400	8000	8400
160	320	9600	9600	9600	8000	9600	8000	9600
185	370	11100	10000	11100	8000	11100	8000	11100
200	400	12000	10000	12000	8000	12000	8000	12000
225	450	12000	10000	12000	8000	12000	8000	12000
280	560	12000	10000	12000	8000	12000	8000	12000
400	800	12000	10000	12000	8000	12000	8000	12000
560	1120	12000	10000	12000	8000	12000	8000	12000
70x	100	3000	3000	3000	3000	3000	3000	3000
100X	140	4200	4200	4200	4200	4200	4200	4200
140X	200	6000	6000	6000	6000	6000	6000	6000
160X	225	6750	6750	6750	6750	6750	6750	6750
185X	260	7800	7800	7800	7800	7800	7800	7800
225X	315	9450	9450	9450	8000	9450	8000	9450
280X	450	12000	10000	12000	8000	12000	8000	12000
400X	560	12000	10000	12000	8000	12000	8000	12000
560X	750	12000	10000	12000	8000	12000	8000	12000

**Note:** Minimum-trip on "X" coils is approximately 140% of continuous ratings.

**Table 5. Duty Cycle**

Type	% of Interrupting Rating	Number of Unit Operations	Maximum Circuit X/R Value
W	15-20	28	3
	45-55	20	7
	90-100	10	14
	Total	58	
WV27	15-20	28	4
	45-55	20	8
	90-100	10	15
	Total	58	
WV38X	15-20	28	4
	45-55	20	8
	90-100	10	15
	Total	58	
VW	15-20	88	4
	45-55	112	8
	90-100	32	15
	Total	232	
VVV27	15-20	88	4
	45-55	112	8
	90-100	32	15
	Total	232	
VVV38X	15-20	88	4
	45-55	112	8
	90-100	32	15
	Total	232	

## Features and detailed description

### Basic recloser design

Eaton's three-phase W-group reclosers are designed to protect circuits on systems operating through 34.5 kV. With the ratings available and the ability of these reclosers to coordinate with other protective equipment, including lower-rated reclosers, they can be applied in a variety of schemes.

The range of protection can be extended by a ground-trip accessory, which provides protection against ground-fault currents that are less than the minimum-trip value of the series coils. Flexibility of application is greatly enhanced by accessories that enable remote control of the recloser.

Closing energy is supplied by a closing solenoid that simultaneously charges the opening springs in preparation for a tripping operation. Fault currents are sensed by trip coils (connected in series with the recloser contacts) that initiate the tripping operation by releasing the opening springs.

Series tripping provides simple and reliable operation because the energy to initiate the tripping operation is taken directly from the line. W-group reclosers are self-contained: they require no external control or control power source.

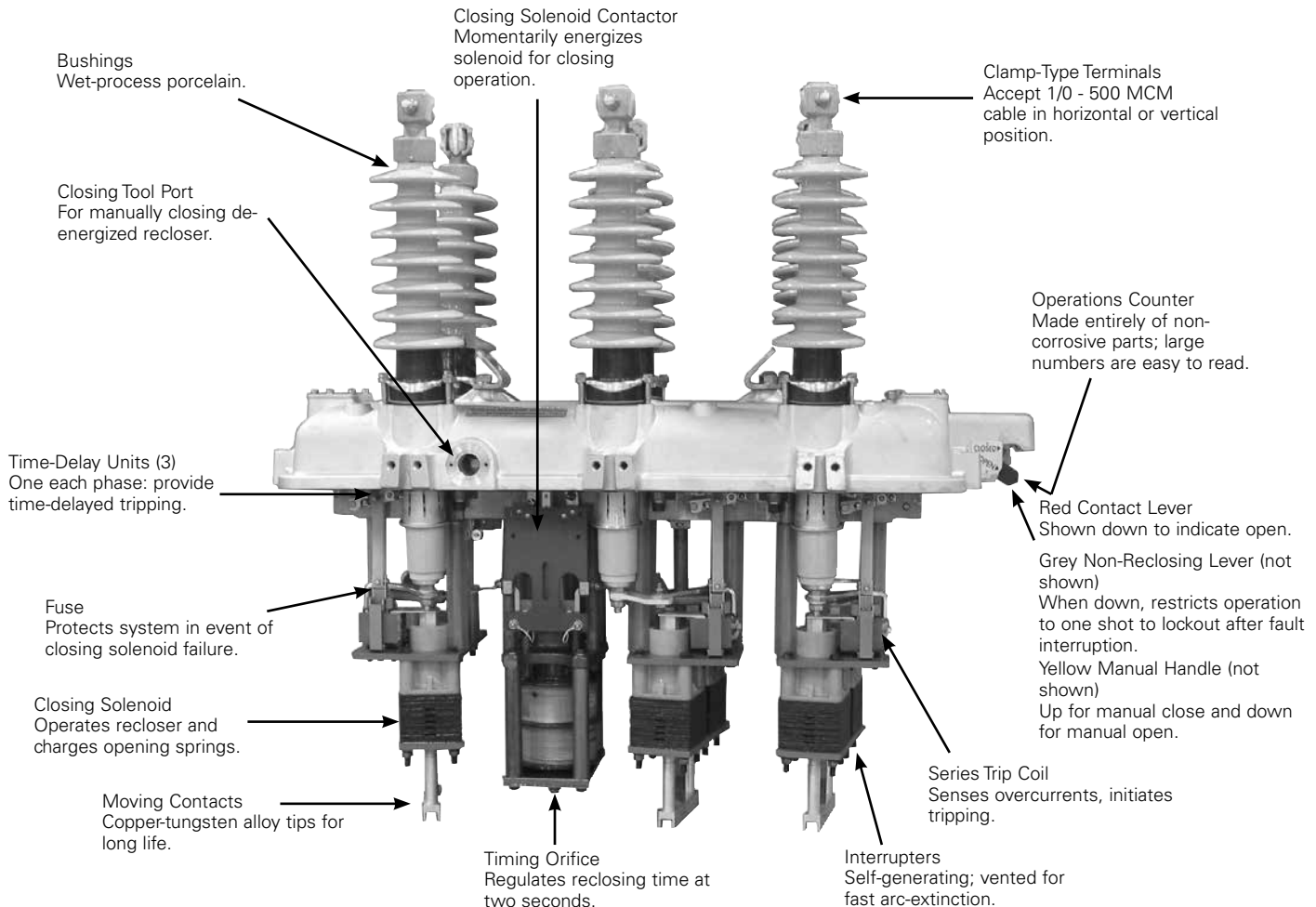
The hydraulic control incorporates separate elements to govern time-delay operations and regulate the number of operations to lockout. The W-group basic design has been proven by more than 50 years of field service.

### Construction

Like all the other reclosers from Eaton, the W-group reclosers are designed for long service life with little maintenance. Heads are aluminum castings. Tanks are heavy-gage steel, finished with light gray polyester powder paint (ASA70). An o-ring gasket confined in a groove, for controlled compression, assures an oil-tight seal between the head and the tank. A 1/2-inch brass oil-sampling and drain valve near the bottom of the tank is standard.

The entire internal mechanism is suspended from the head casting so that the mechanism and the head assembly can be removed from the tank as a unit. Reclosers are mounted by brackets that can be attached to the head casting. This permits easy access to the contacts and the mechanism in the field by lowering the tank with a wire-rope winch, which is available as an accessory.

The insulating supports from which the three interrupters are suspended are filament-wound glass epoxy for high electrical and mechanical strength and moisture resistance.



**Figure 1. Untanked Type WV recloser shown from series trip coil side. Construction of Types WV27, WV38X, VW, VVW27, and VVW38X is similar except for the vacuum interrupters on VW, VVW27, and VVW38X; see Figure 2.**

## Operation

### Series trip coil

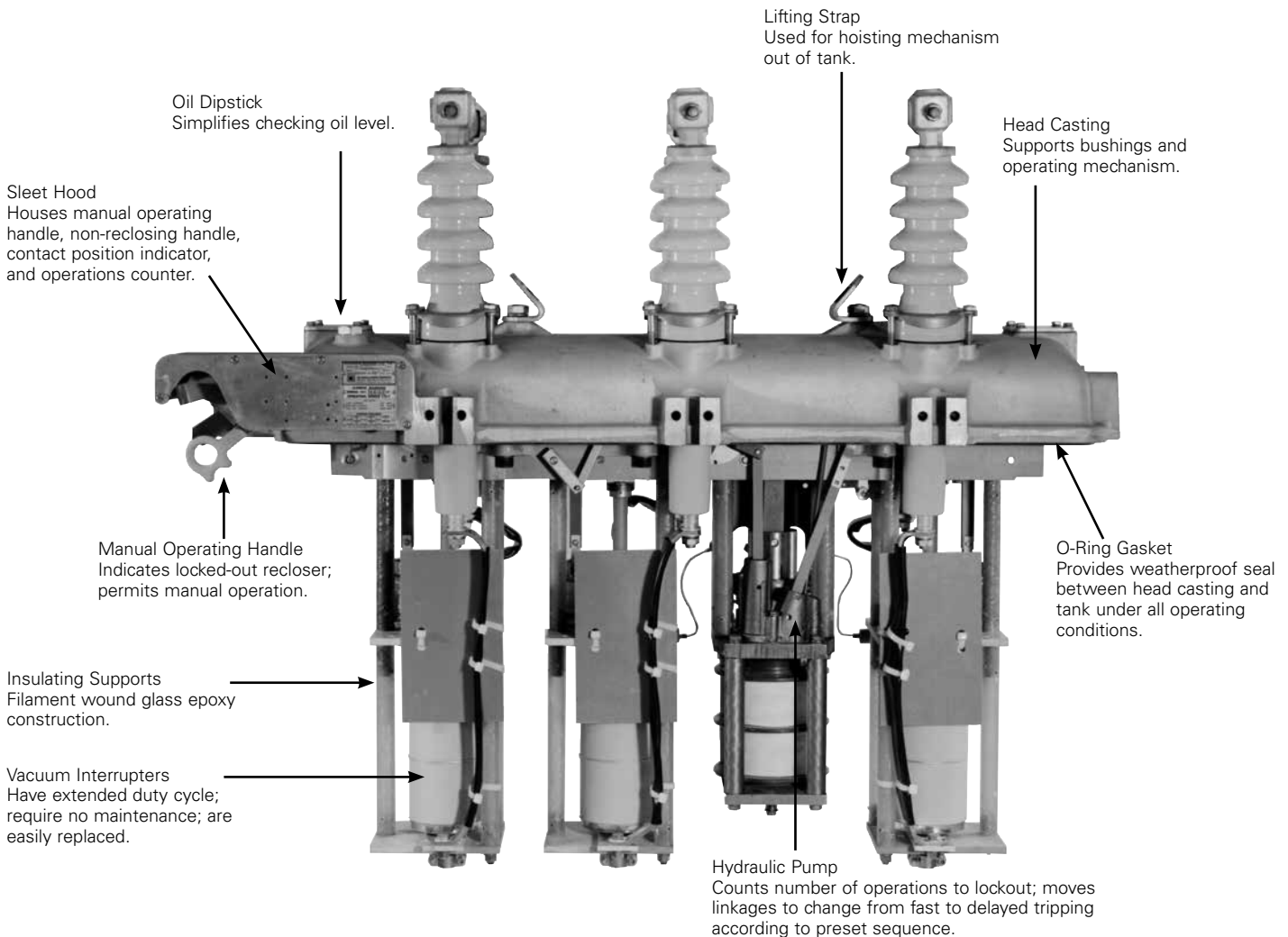
Fault current in the W-group is sensed by the three trip coils that are connected in series with the recloser contacts and can carry line current up to their rating. Coils of applicable ratings are interchangeable among the W-group reclosers. Continuous current and minimum trip ratings can be changed by replacing the coils.

When fault current in excess of the minimum trip ratings flows on one or more phases, the trip solenoid plunger, which is normally held at rest by the mechanism, is drawn into the coil by the magnetic effect generated by the fault current.

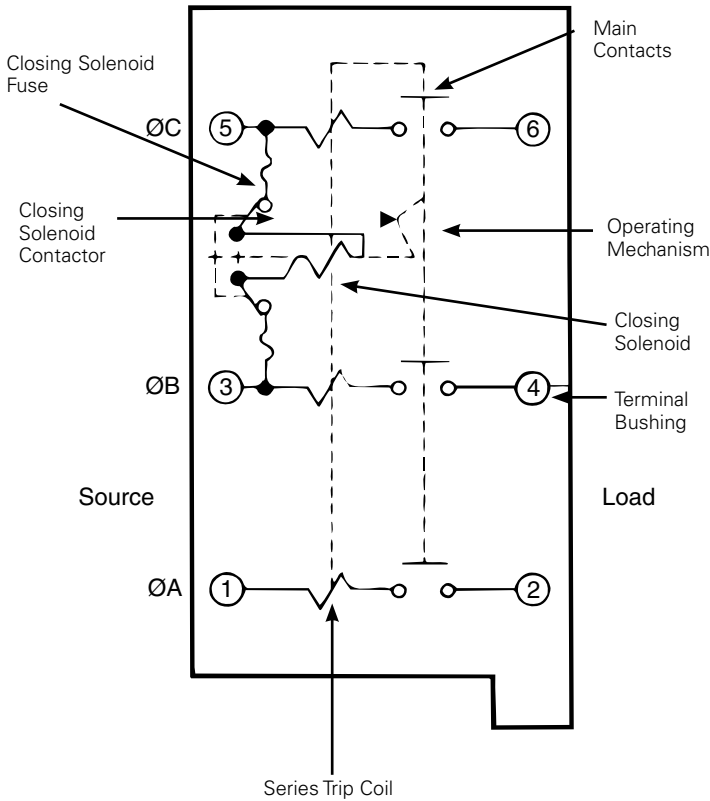
Near the end of the downward stroke, a linkage connected to the trip plunger trips a latch that releases the charged opening springs and the recloser contacts are opened.

The series trip coil is surge-protected by a shunting bypass gap on reclosers with trip coils rated below 100 A.

Independent fault detection on each phase is provided by separate trip coils. A common bar trips all three phases, preventing single-phase supply to three-phase loads. A trip coil carrying a higher fault current will override and cause faster tripping than a phase experiencing a lower fault current.



**Figure 2. Untanked view of a VW recloser shown from hydraulic pump side.**



### Closing solenoid

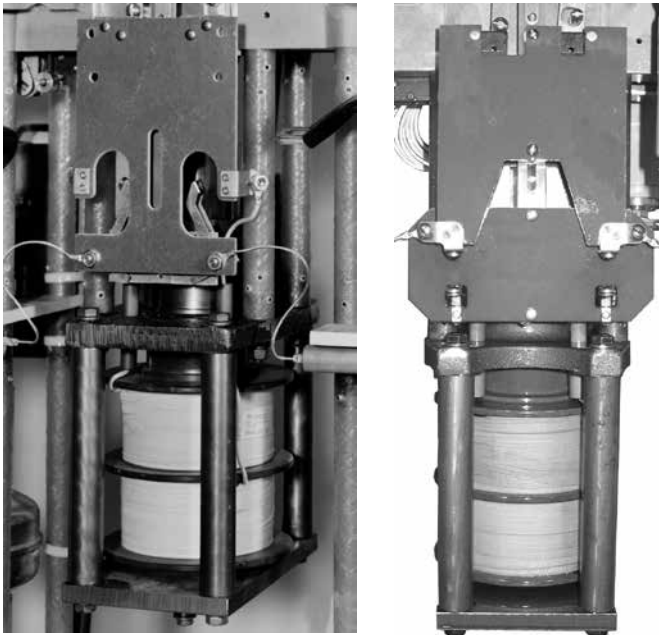
Closing energy, as well as the energy to charge the opening springs in the W-group reclosers, is supplied by a high-voltage closing solenoid, which is connected phase-to-phase and energized through a contactor. When the recloser contacts are closed, the solenoid plunger is latched in the down position. This latch is tripped simultaneously with the release of the opening springs and the solenoid plunger moves upward. A timing orifice in the bottom of the solenoid-plunger cylinder regulates the rate at which upward movement can take place as oil is drawn into the cylinder.

As the solenoid plunger reaches the top of its stroke, the high-voltage line contactor energizes the closing solenoid, pulling the plunger down. The closing solenoid contactor opens, de-energizing the coil, and, through the mechanical linkage, the main contact-operating rods are simultaneously moved upward to close the contacts. At the same time, the opening springs are charged in preparation for a tripping operation.

W, WV27, VW, and VVW27 reclosers, which are rated through 24.9 kV, are equipped with a high-voltage closing solenoid contactor with two breaks in series. The higher rated reclosers, WV38X and VVW38X, are equipped with a contactor with four breaks in series.

Control of the upward travel of the plunger regulates reclosing time. Normal reclosing time for the W-group reclosers is two seconds. The first reclosing operation in the programmed sequence can be 30 or 45 cycles when the dual-reclosing accessory is used.

**Figure 3. Phase-to-phase connection of high-voltage closing solenoid.**



Types W, WV27, VW, VVW27 reclosers      Types WV38X and VVW38X reclosers with 30 kV, 33 kV, or 34.5 kV closing solenoid coil.

**Figure 4. High-voltage closing solenoid contactors.**

### Hydraulic control system operation

The number and sequence of operations to lockout and the time-delay operations are controlled by two separate hydraulic mechanisms which are mechanically linked.

#### Pump-and-Lockout-Piston assembly

The hydraulic pump, associated cam, and linkages regulate the number of fast and delayed operations, count the operations to lockout, and, after a preset number of operations, initiate lockout.

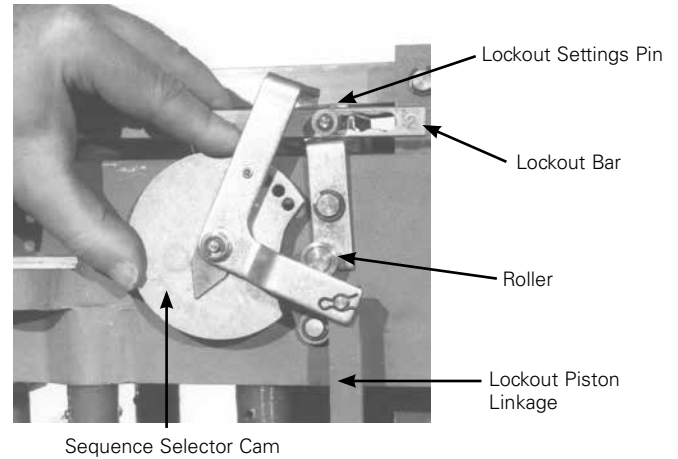
The hydraulic pump (Figure 5) is linked to the closing solenoid plunger and pushed downward with each return operation of the plunger. With its downward stroke, the pump forces a measured amount of fluid under the lockout piston, causing it to rise one step. Ball-type check valves retain the charge. When the closing solenoid is energized, the recloser contacts close and the pump returns to its normal position.

The lockout piston is linked to the sequence selector cam (Figure 6) and the lockout bar. Upward movement of the lockout piston causes the cam to rotate counterclockwise and the lockout bar to advance one step. The number of fast operations are preset on the cam.

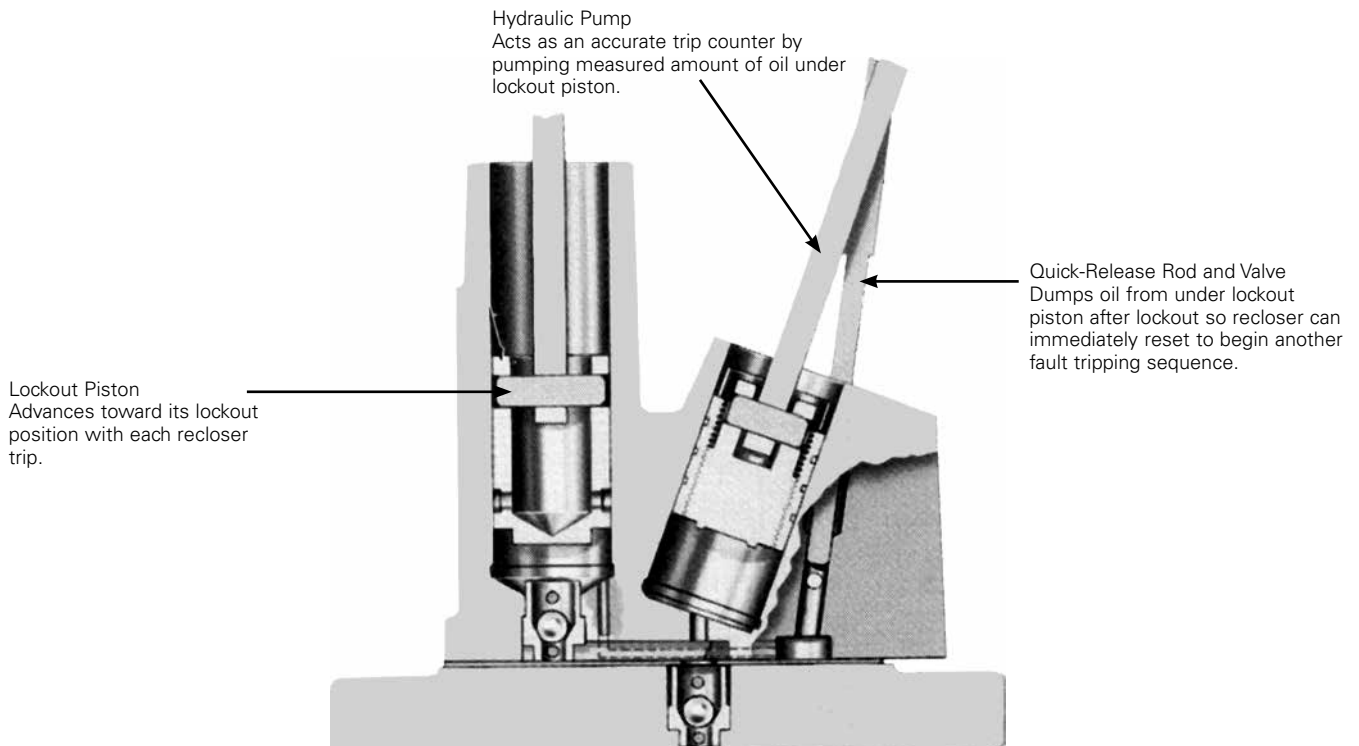
After these operations, the cam edge engages the roller and pushes it to the right. A mechanism arm attached to the roller engages the time-delay mechanism on each phase. Subsequent operations are then delayed.

When the lockout bar completes its travel, it trips the lockout latch through another set of linkages and springs lock the recloser contacts open. The reset rod and valve (Figure 5) are raised, releasing hydraulic fluid from beneath the lockout piston so that it resets quickly. The entire pump and sequencing mechanism are now ready for the next full sequence of operations.

For temporary faults that are cleared before the recloser mechanism reaches lockout, the lockout piston resettles gradually (at a rate of approximately 90 seconds per operation at 25°C) to reset the recloser mechanism.



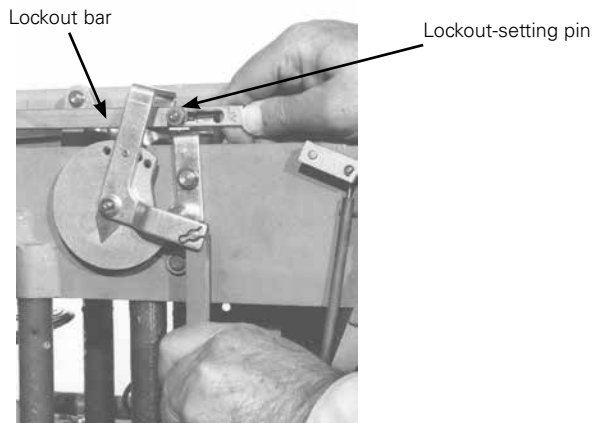
**Figure 6. Recloser operating sequence is determined by the number of fast operations programmed on the sequence selector cam. The number of delayed operations will be the balance of operations to lockout. The setting on the sequence selector cam is easily changed in the field.**



**Figure 5. Cross-section of hydraulic pump.**

### Operating settings

The required sequence of fast and delayed operations and the required number of operations to lockout are factory set per customer specification. Either or both settings are easily changed in the field; only a partial untanking of the recloser is necessary and no special tools are needed.



**Figure 7.** The internal setting for the number of operations to lockout (two, three, or four) is achieved by positioning the lockout-setting pin in one of three notches in the lockout bar. This setting is easily changed in the field.

Internal settings for the number of operations to lockout permit the recloser to be programmed for two, three, or four trip operations to lockout. Programming for one operation to lockout is done with the external non-reclosing handle located under the sleet hood. The internal setting is easily changed by moving the horizontal lockout bar (Figure 7) to index the lockout-setting pin in the required notch.

Moving the external non-reclosing handle down activates the non-reclosing feature (one operation to lockout); this overrides the internal setting but does not change it physically. When the non-reclosing feature is deactivated (handle moved up), the number of operations to lockout automatically reverts to the internal setting, providing complete flexibility for testing or service without disturbing the programmed operations-to-lockout setting.

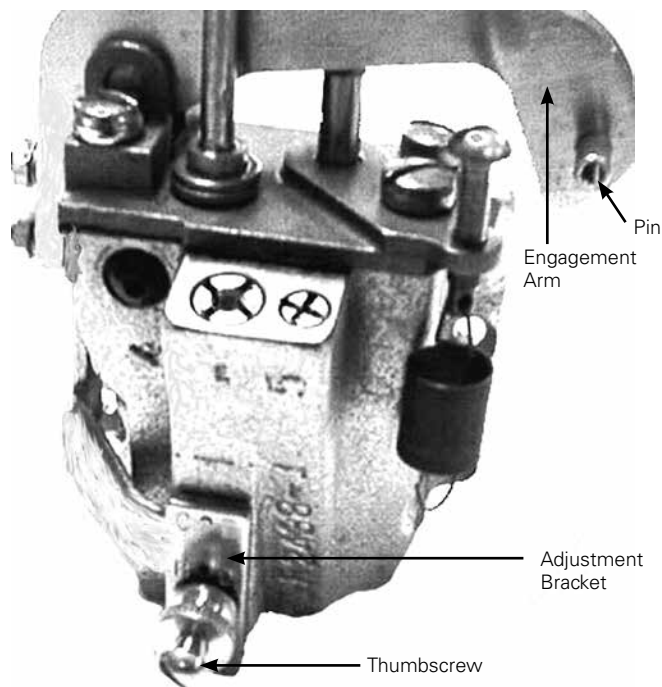
The timing of recloser trip operations can be fast (which includes no intentional time delay), delayed (which follows one of four slower time-current characteristics), or a sequence of fast followed by delayed.

The recloser mechanism is programmed simply by setting the number of fast operations required in each sequence of operations to lockout, by indexing a notched cam to the required number (Figure 6).

It is easily changed by lifting the flat spring tab away from the cam and rotating the cam until the desired number of fast operations is indicated. The setting for the number of fast operations determines the number of delayed operations in the sequence; for example, if four operations to lockout are selected and the cam is adjusted for two fast operations, the sequence will be two fast operations followed by two delayed.

### Time-delay mechanism

Delayed operations in W-group reclosers are established by the hydraulic time-delay mechanism on each phase. The time-delay mechanism is engaged with time-current characteristic. The selected curve is established by the time of engagement of the time-delay mechanism. For the B and D curves, approximately half of the stroke is unimpeded, then the trip coil linkage engages the time-delay mechanism and the remainder of the stroke is impeded, establishing the desired curve. With the slower (C and E) curves, the time of engagement is earlier.



**Figure 8.** Changing time-current characteristics to the alternate curve is accomplished by loosening the thumbscrew and indexing the adjustment bracket to the proper hole.

The time-delay mechanism permits a choice of two characteristics: B and C or D and E. The time-delay curves will be set at the factory as specified. Adjustment from one characteristic to the other is made by indexing a thumbscrew-and-bracket arrangement on the time-delay mechanism to change the curve by changing the time of engagement (Figure 8).

### Established delay operations

Operation of the time-delay mechanism is initiated by the integrating mechanism. As the indexing cam (Figure 6) is rotated counterclockwise by the upward movement of the lockout piston, it engages a roller assembly, causing the solenoid linkage engagement arm to pivot clockwise, placing its hook above the pin on the time-delay arm. When an overcurrent occurs and the engagement arm moves downward with the trip coil linkage, the hook engages the pin on the time-delay arm and the time-delay mechanism impedes the remainder of the stroke.

### Operation

The hydraulic time-delay mechanism piston is pulled downward by the trip coil linkage. A floating plate (retained by an open basket) at the bottom of the hollow piston functions as a one-way valve on the downstroke, sealing the bottom of the piston.

On low-current operations, displaced oil is forced around the grooved pin in the low-current valve and is allowed to return to the space above the piston. When a higher current fault is interrupted, increased oil pressure raises the springloaded valve so that oil flows through both valves and the tripping operation is accelerated proportionately.

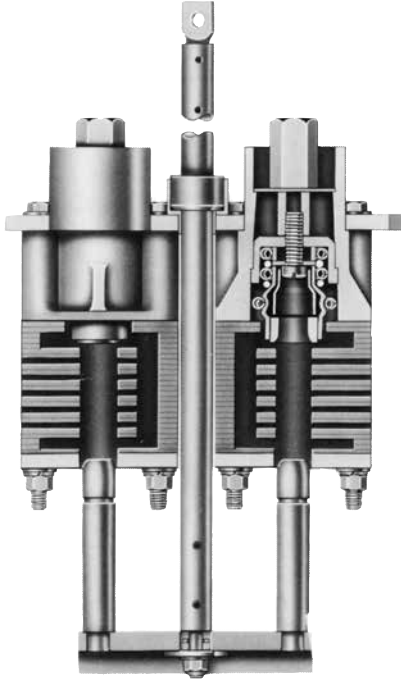
The hydraulic time-delay mechanism has no effect on contact-opening speed, it only delays the moment at which the opening springs are released.



## Interrupter construction

### Oil interrupters

Fast arc interruption (down to 2-1/2 cycles clearing) is achieved by bridge-type contacts that provide two current breaks in series per phase. The bayonet-type moving contacts are silver-plated tungsten alloy for erosion resistance and good conductance. The stationary contact assemblies are tulip-type clusters of silver-plated contact fingers held together by garter springs. The contacts are self-cleaned by the opening and closing wiping action.



**Figure 9. General construction of a typical self-generating interrupter used in oil interrupting reclosers.**

Each current break is provided with a self-generating arc interrupter structure which includes a series of vented chambers. As the contacts open, the arc generates gas pressure in the upper chamber that blasts oil across the arc and out through the vents. As a result, arc extinction is fast and arc energy levels do not increase as fast at the higher fault-current levels.

### Vacuum interrupters

Vacuum interrupters provide fast, low-energy arc interruption with long contact and interrupter life, low mechanical stress, and maximum operating safety. With arc interruption taking place in a vacuum, contact and interrupter life are several times greater than with interruption in oil, and interrupter maintenance is virtually eliminated. Because of the shorter contact stroke, mechanical stress and wear on the mechanism is substantially reduced.

Vacuum interrupters are designed with a metal and ceramic housing for maximum strength and long-term vacuum integrity. The high-alumina ceramic has more than five times the strength of glass, permits a higher processing temperature to develop maximum purity of the assembly, and is impervious to helium penetration to sustain the vacuum level. Metal end-closures and the arcing chambers are of high-purity alloy to minimize contamination.

Enclosed in the interrupter is a stationary and a moving contact assembly. The moving contact has a travel of approximately one-half inch, its shaft passing through a flexible bellows which maintains vacuum integrity. Contacts are made of a special non-welding alloy.

Because the smallest amount of internal contamination can significantly shorten the life of a vacuum interrupter, a clean-room facility is used for interrupter production. Special care is taken to avoid even minute contamination from any source, whether it be dust particles, machining oils, or human body salts.



**Figure 10. General construction of a typical vacuum interrupter used in vacuum interrupting reclosers.**

## Accessories

W-group reclosers can be supplemented with a number of accessories to provide added application flexibility. Some accessories modify the normal operating functions while others increase operating versatility; still others provide indicating functions. For each accessory installed on a particular recloser, a data plate is mounted on the sleet hood of the recloser.

Where required, accessory leads are brought into the recloser tank through a junction box mounted on the head casting.

### Bushing-type, multi-ratio current transformers

Multi-ratio current transformers for operating meters or separate relays can be mounted on load-side bushings 2, 4, and 6 or the source-side bushings 1, 3, and 5 (Figure 11). These current transformers have only one primary turn – the bushing rod. They are available with secondary windings that provide primary/secondary-current ratios of either 600:5 or 1200:5. Different ratios can be obtained by connection to appropriate taps on their secondary windings.

Ratios obtainable from 600:5 and 1200:5 transformers are shown in Table 6.



Figure 11. Multi-ratio current transformers mounted on the source-side bushings.

Table 6. Bushing-Type Multi-Ratio Current Transformer Ratios and Terminal Connection

Ratio	Ratio	Terminal Connection
50:5	100:5	X2 - X3
100:5	200:5	X1 - X2
150:5	300:5	X1 - X3
200:5	400:5	X4 - X5
250:5	500:5	X3 - X4
300:5	600:5	X2 - X4
400:5	800:5	X1 - X4
450:5	900:5	X3 - X5
500:5	1000:5	X2 - X5
600:5	1200:5	X1 - X5

### Hydraulic ground-trip accessory

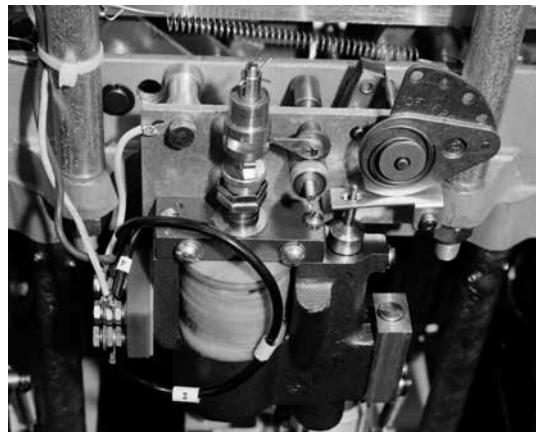


Figure 12. Ground-trip coil mounted in recloser.

If the rated minimum zero-sequence (ground) current is exceeded, the hydraulic ground-trip mechanism, an oil-dashpot-type solenoid connected to paralleled BCT secondaries, trips the recloser. The hydraulic ground-trip mechanism accessory enables the recloser to protect against ground-fault currents lower than the recloser's minimum phase-trip setting. For currents above the minimum phase-trip setting, recloser opening is governed by either the phase-trip series coil or the ground-trip coil, whichever is faster. Refer to Reference Data R280-91-7 for available delay curves.

The ground trip coil is operated from the bushing-type, multi-ratio current transformers mounted on the source-side bushings (1, 3, and 5) to produce the minimum ground-trip currents shown in Table 7. The current transformers must be ordered separately.

Table 7. Ground-Trip Operating Data

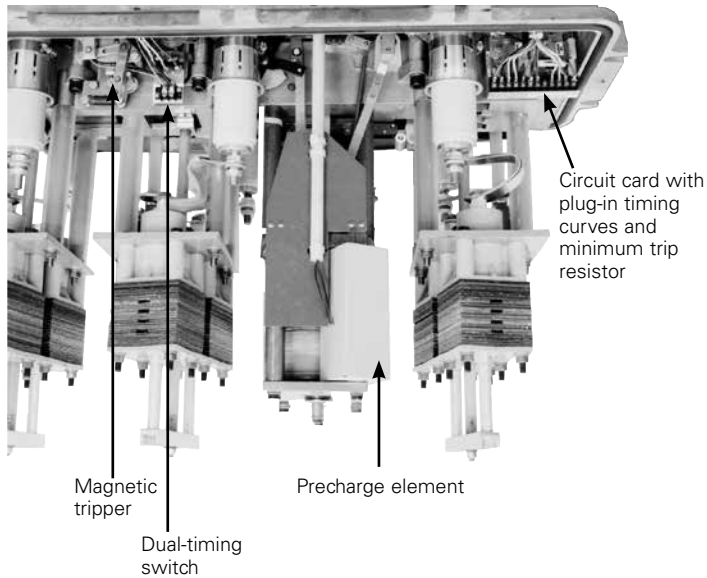
Bushing Current Transformer Ratio	Minimum Zero-Sequence Trip Current (primary A)	
	Series Connected Coil	Parallel-Connected Coil
50:5	N/A*	N/A*
100:5	63.5	110
150:5	87	156
200:5	110	204
250:5	133	250
300:5	156	300
400:5	204	400
450:5	227	450
500:5	250	500
600:5	300	600

\* Not applicable: BCT output too low to operate solenoid.

### Electronic ground-trip accessory

Self-contained, independent, sensitive ground-fault tripping is also available with an electronically controlled ground-trip accessory that includes the following:

- Fifteen fault-timing characteristics including inverse and definite-time curves, or plug-in modules that are easily field changed.
- Dual-timing capability.
- Twelve minimum-trip levels, from 5 to 400 A.
- Line powered; completely self-contained.
- Precharging coil for consistent timings even when reclosing on a permanent fault.



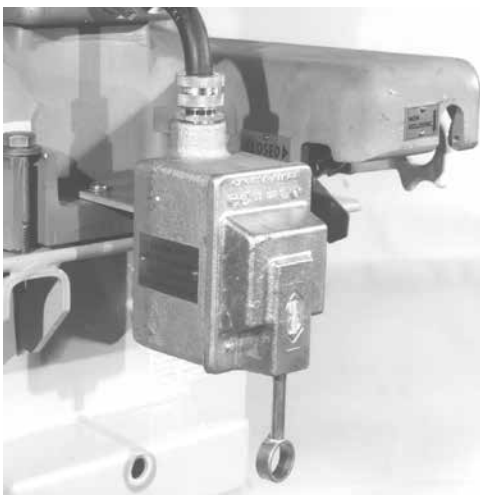
**Figure 13. Components of electronic ground-fault trip accessory.**

Fault-timing characteristics and timing operations are independent and separate from the recloser's phase fault timing and TCCs. Counting to lockout is integrated with phase operations. The dual-timing feature enables coordination with other protective apparatus on the system.

Accessory control circuits are powered from the line through two current transformers mounted under the head casting on source-side bushings (Figure 13). Five amperes of line current is all that is required to maintain circuit charge and supply the trip operation.

Zero-sequence (ground) current is sensed by three parallel-connected current-sensing transformers mounted beneath the head casting on the load-side bushings. When the ground current exceeds the selected minimum-trip level, the control circuits actuate the magnetic tripper to trip the recloser. Ground overcurrent timing is according to the time-current characteristics programmed with plug-in modules on the accessory circuit board.

When the recloser automatically recloses or is otherwise closed by electrical operation of its closing solenoid, an initial arming feature instantly charges the accessory control circuits. This enables the ground-trip accessory to respond immediately, according to its programmed time-current characteristic, should a ground fault be present.



**Figure 14. Ground-trip blocking switch; hotstick-operated.**

If the system downline from the recloser is energized by other than electrical operation of the recloser (such as the closing of an upline recloser or breaker), control-circuit arming time must be added to the published time-current characteristic for proper TCC coordination. Further information that can be used in anticipating such circumstances is found with the published time-current characteristics on this accessory; refer to *Reference Data R280-91-12, Types RX, RV, W, WV, VW, VVV Time-Current Curves*.

#### Ground-trip blocking switch

A ground-trip blocking switch can be provided for either ground-trip accessory. The hotstick-operated blocking switch (Figure 14) is normally mounted on the recloser. The manual lever-operated blocking switch (Figure 16) is for remote mounting.



**Figure 15. Ground-trip blocking switch for remote manual operation.**

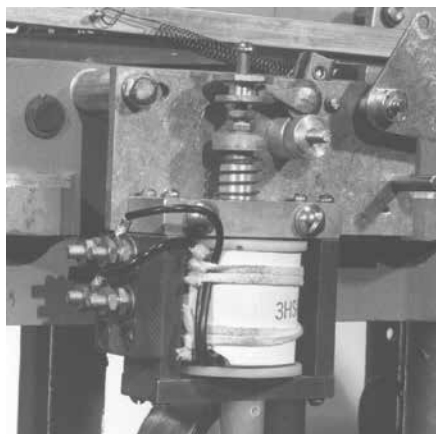


Figure 16. Remote trip solenoid.

### Remote trip

When energized from an external source, the remote trip accessory (Figure 16) trips the recloser, just as when the series trip coil operates. Normal automatic reclosing follows. Reclosing will occur even if the solenoid remains energized. Should this condition occur, the recloser will operate to lockout. The remote trip accessory leads are brought out of the recloser tank through a separately specified accessory junction box.

Electrical ratings are shown in Table 8.

**Note:** The remote trip accessory cannot be installed on a recloser equipped with a ground-trip accessory (hydraulic or electronic) since both occupy the same space and operate the same trip-lever mechanism.

**Table 8. Electrical Ratings of Remote Trip Accessory; Intermittent Duty Only**

Rated Voltage (Vac)	Operating Voltage Range (Vac)	Steady-State Current at Rated Voltage (A)
120	95-125	1.3
240	190-250	0.65

### Low-voltage DC closing

By specifying a DC-closing solenoid from Table 17 and this accessory, the recloser can be closed by an externally controlled low-voltage DC power source rather than from the primary high-voltage source. A separately specified accessory junction box with input terminal block is also required. Low voltage is especially desirable in loop and load-transfer schemes where the recloser can be operated regardless of which side of the unit is energized. Current requirements for DC closing are 55 A at 125 Vdc or 58 A at 48 Vdc.

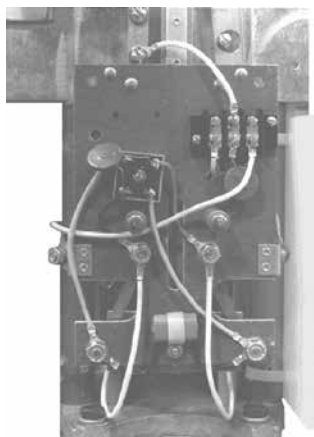


Figure 17. Low-voltage AC closing accessory.

**Table 9. Interrupting Ratings of Auxiliary Switch**

Volts (AC or DC)	Inductive AC (A)	Non-Inductive AC (A)	Inductive DC (A)	Non-Inductive DC (A)
24	–	–	15	20
48	–	–	7.5	10
120	50	80	–	–
125	–	–	1.5	2
240	25	40	–	–
250	–	–	0.45	0.5

### Low-voltage AC closing

With the addition of a modified closing contactor equipped with a full-wave diode bridge (Figure 17), the DC closing solenoid can be operated from a low-voltage AC source. Current requirements for AC closing are 51 A at 120 Vac or 34 A at 240 Vac.

### Auxiliary switch

Remote indication of recloser contact position or switching of other devices can be accomplished with an auxiliary switch. A three-stage switch is mounted on the recloser (Figure 18). Each stage has two independent contacts a and/or b. When the recloser's main contacts are open, the a contacts are also open and the b contacts are closed. Table 10 shows the recloser/ auxiliary switch contact relationship.

Switch contacts are insulated for 600 V and have a continuous current rating of 10 A. The interrupting ratings of the auxiliary switch contacts are shown in Table 9 above.



Figure 18. Auxiliary switch (with cover removed).

**Table 10. Recloser/Auxiliary Switch Contact Positions**

Recloser Contacts	Auxiliary Switch	
	Contact A	Contact B
CLOSED	CLOSED	OPEN
OPEN	OPEN	CLOSED

### Lockout-indicating switch

A lockout-indicating switch assembly can be added for remote indication of recloser lockout (Figure 19). The switch is particularly useful in load-transfer schemes.

Consisting of two single-pole, double-throw switches in a weatherproof housing, the assembly is actuated by the recloser's manual operating lever. A threaded opening for a one-half inch IPS conduit or cable grip is provided.

Electrical ratings of the lockout-indicating switch are shown in Table 11.

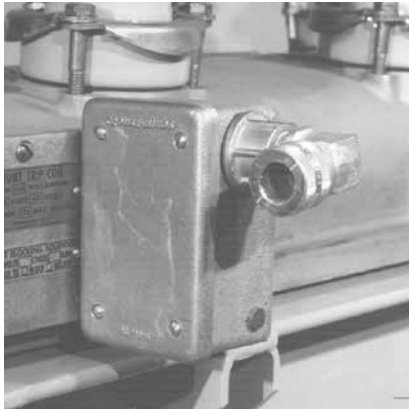


Figure 19. Lockout-indicating switch.

Table 11. Electrical Ratings of Lockout-Indicating Switch Accessory

Interrupting Rating (A)	Operating Voltage
10	120 Vac
5	240 Vac
0.5	125 Vdc
0.25	250 Vdc

### Remote lockout

The remote lockout accessory (Figure 20) enables an external control to trip the recloser and operate the lockout mechanism.

The remote lockout accessory leads are brought out of the recloser tank through a separately specified accessory junction box with terminal block.

Electrical ratings of the remote lock-out accessory are shown in Table 12.

**Note:** To provide complete remote operation, the remote lockout accessory is usually employed with the remote close accessory.

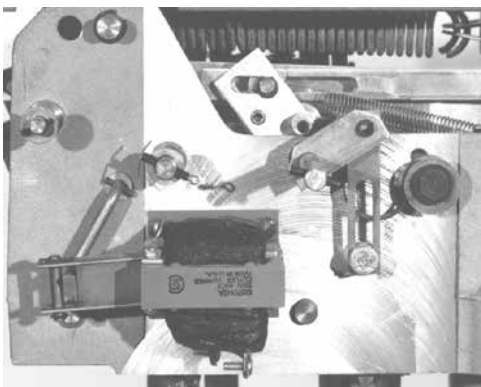


Figure 20. Remote lockout solenoid.

Table 12. Electrical Ratings of Remote Lockout Accessory

Rated Voltage (Vac)	Operating Voltage Range (Vac)	Steady-State Current at Rated Voltage (A)
115	95-125	0.36
230	190-250	0.18

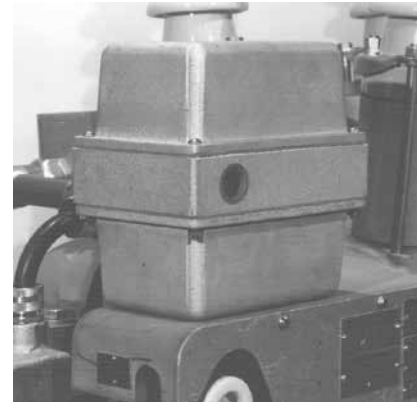


Figure 21. Remote closing solenoid.

### Remote close

When energized from an external source, the remote close accessory closes a locked-out recloser by manually pulling the operating handle to the CLOSE position, actuating the high-voltage closing solenoid contactor to close the recloser. The external control circuit for this accessory requires a connection that includes a customer-furnished, normally open, momentary contact switch wired in series with the solenoid.

Electrical ratings of the remote close of locked-out recloser accessory are shown in Table 13.

**Note:** When this accessory is added to a recloser, the recloser cannot lockout if the remote close accessory is held energized.

Table 13. Electrical Ratings of Remote Close Accessory

Rated Voltage (Vac)	Operating Voltage-Range (Vac)	Current at Rated Voltage (A)	
		Inrush	Steady-State
115	100-125	32-34	3.25
230	200-250	16-18	1.67

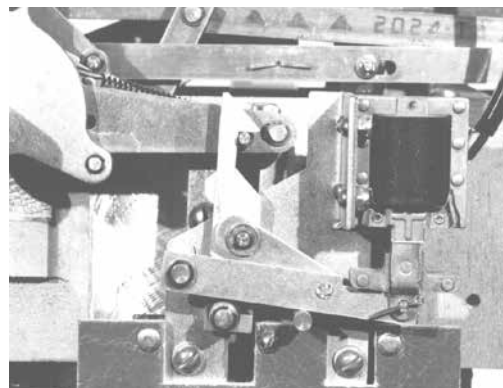
**Remote block of closing**

The remote block of closing accessory enables remote control of closing (Figure 22). One type blocks closing when the solenoid is energized; the other blocks closing when the solenoid is de-energized.

Electrical ratings of the remote block of closing accessory are shown in Table 14.

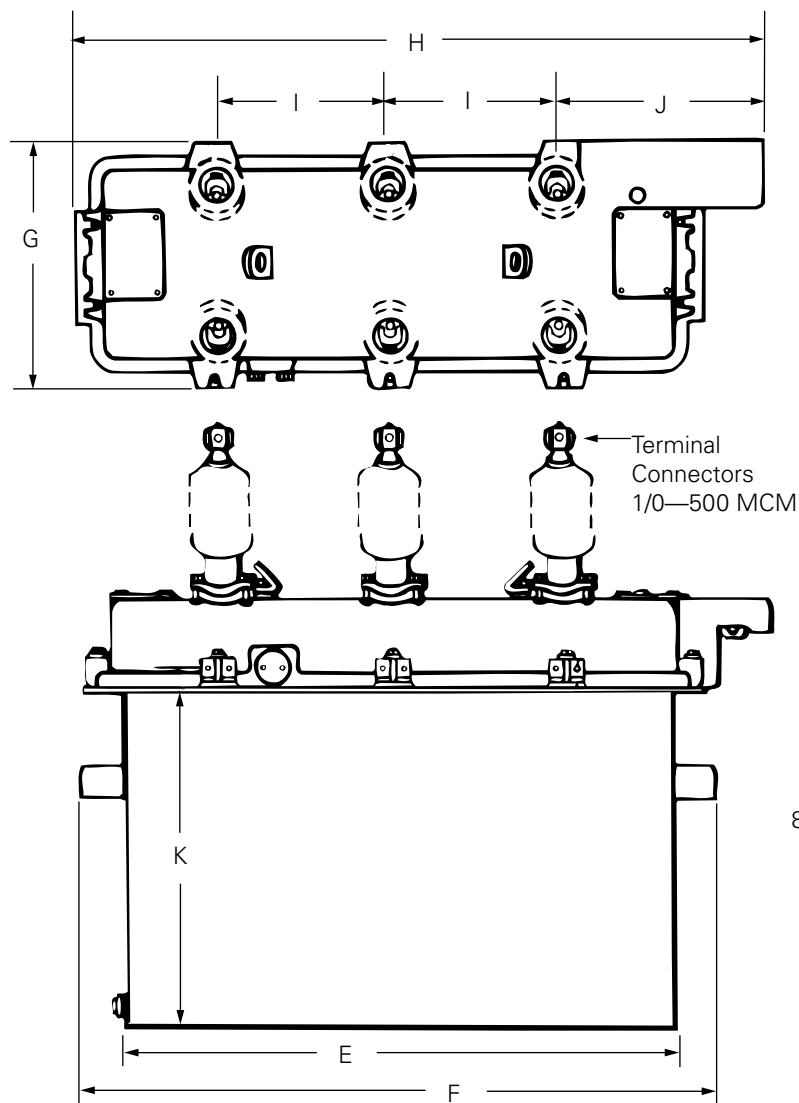
**Table 14. Electrical Ratings of Remote Block of Closing Accessory**

Rated Voltage (Vac)	Operating Voltage Range (Vac)	Steady-State Current (A)	Status
115	95-125	0.2	Blocks when de-energized
230	190-250	0.1	
115	95-125	0.2	Blocks when energized
230	190-250	0.1	

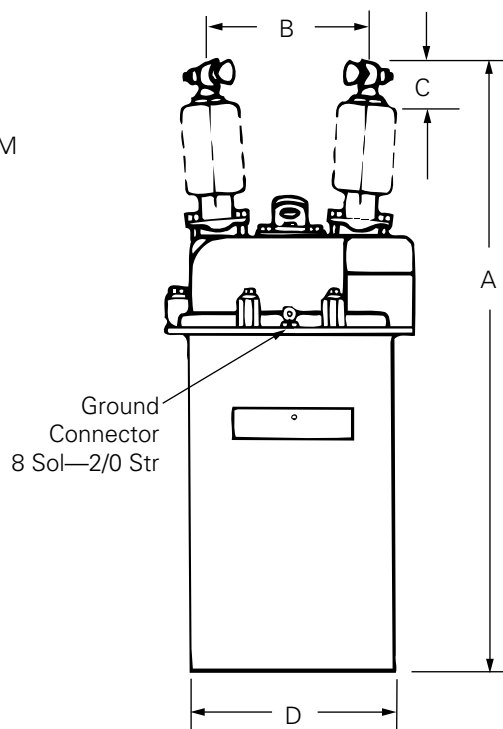


**Figure 22. Remote block of closing solenoid.**

**Dimensions and weights**



**Note:** For dimensions of reclosers with mountings, see Service Information MN280039EN Recloser Mountings.



**Figure 23. Dimensions of W-group reclosers.**

**Table 15. Overall Dimensions mm (in.)**

Recloser Type	Without bushing current transformer accessory	Dim A	Dim B	Dim C	Dim D	Dim E	Dim F	Dim G	Dim H	Dim I*	Dim J	Dim K
W	Standard 13 in. creepage or 17-in. extra-creepage bushings	1057 41-5/8	283 11-1/8	79 3-1/8	333 13-3/8	933 36-3/4	1076 42-3/8	435 17-1/8	1172 46-1/8	289 11-3/8	343 13-1/2	676 26-5/8
VV		1114 43-7/8	283 11-1/8	79 3-1/8	333 13-1/8	933 36-3/4	1076 42-3/8	435 17-1/8	1172 46-1/8	289 11-3/8	343 13-1/2	733 28-7/8
WV27	Standard 26-1/2-in. creepage bushings	1213 47-3/4	302 11-7/8	105 4-1/8	333 13-1/8	933 36-3/4	1076 42-3/8	435 17-1/8	1172 46-1/8	289 11-3/8	343 13-1/2	676 26-5/8
VVV27		1270 50	302 11-7/8	105 4-1/8	333 13-1/8	933 36-3/4	1076 42-3/8	435 17-1/8	1172 46-1/8	289 11-3/8	343 13-1/2	733 28-7/8
WV38X		1197 47-1/8	381 15	105 4-1/8	438 17-1/4	940 37	1083 42-5/8	540 21-1/4	1178 46-3/8	384 15-1/8	254 10	676 26-5/8
VVV38X		1254 49-3/8	381 15	105 4-1/8	438 17-1/4	940 37	1083 42-5/8	540 21-1/4	1178 46-3/8	384 15-1/8	254 10	733 28-7/8
Recloser Type	With bushing current transformer accessory	Dim A	Dim B	Dim C	Dim D	Dim E	Dim F	Dim G	Dim H	Dim I*	Dim J	Dim K
W	Standard 13 in. creepage or 17-in. extra-creepage bushings	1178 46-3/8	302 11-7/8	79 3-1/8	333 13-1/8	933 36-3/4	1076 42-3/8	435 17-1/8	1172 46-1/8	289 11-3/8	343 13-1/2	676 26-5/8
VV		1235 48-5/8	302 11-7/8	79 3-1/8	333 13-1/8	933 36-3/4	1076 42-3/8	435 17-1/8	1172 46-1/8	289 11-3/8	343 13-1/2	733 28-7/8
WV27	Standard 26-1/2-in. creepage bushings	1334 52-1/2	321 12-5/8	105 4-1/8	333 13-1/8	933 36-3/4	1076 42-3/8	435 17-1/8	1172 46-1/8	289 11-3/8	343 13-1/2	676 26-5/8
VVV27		1391 54-3/4	321 12-5/8	105 4-1/8	333 13-1/8	933 36-3/4	1076 42-3/8	435 17-1/8	1172 46-1/8	289 11-3/8	343 13-1/2	733 28-7/8
WV38X		1314 51-3/4	403 15-7/8	105 4-1/8	438 17-1/4	940 37	1083 42-5/8	540 21-1/4	1178 46-3/8	397 15-5/8	241 9-1/2	676 26-5/8
VVV38X		1375 54-1/8	403 15-7/8	105 4-1/8	438 17-1/4	940 37	1083 42-5/8	540 21-1/4	1178 46-3/8	397 15-5/8	241 9-1/2	733 28-7/8

\* Dim. I is the distance between bushings (centerline-to-centerline.)

**Table 16. Weights and Oil Capacity**

Recloser Type	Weight with Oil* kg (lb.)	Oil Capacitor L (gal)
W	356 (785)	144 (38)
WV27	359 (790)	156 (41)
WV38X	459 (1012)	201 (53)
VV	384 (845)	156 (41)
VVV27	384 (845)	171 (45)
VVV38X	422 (930)	224 (59)

\* Add 11 kg (25 lb) for each bushing current transformer.

### Constructing a catalog number

To order a basic Type VW recloser with a 560 trip coil, a 750 A minimum-trip current, a B time-current curve, with two fast and two delayed operations to lockout for service on a 12.0-13.2 kV system, the catalog number would be constructed like this:

#### KVW

Basic letters for a Type VW recloser  
Basic letters for other reclosers:

Type W: KW  
Type WV27 KVV27  
Type WV38X KVV38X  
Type VW KVW  
Type VVV27 KVVV27  
Type VVV38X KVVV38X

**560** Continuous current rating of series-trip coils: 5, 10, 15, 25, 35, 50, 70, 100, 140, 160, 185, 200, 225, 280, 400, or 560 A. (Minimum-trip current is 200% of continuous rating.)

**X** Insert letter X **only** if a type X series trip coil is used; otherwise omit letter. Continuous current rating of X series trip coils: 70, 100, 140, 160, 185, 225, 280, 400, or 560 A. (Minimum-trip current is 140% of continuous rating.)

**B** Delayed time-current curve desired: B, C, D, or E. If all fast operations are required, insert letter A.

**2** Number of fast A-curve operations: 0, 1, 2, 3, or 4.

**2** Number of delayed operations: 0, 1, 2, 3, or 4.

**4** Closing solenoid voltage code number selected from Table 17 for the system on which the recloser is to be used.

*Fast+delayed  
operations not  
to exceed four*

**KVW 560 X B 2 2 4**

*KVV560XB224 is the catalog number for the required basic recloser.*

### Ordering information

To order a basic W-group recloser, use the chart above and Table 17 to construct a catalog number that describes the required recloser. Order accessories and mounting equipment from Tables 18 through 30.

Construction of a catalog number requires:

1. Recloser Type: W, WV27, WV38X, VW, VVV27, or VVV38X.
2. Series trip coil continuous current rating.
3. Need for series trip coil with a minimum trip current rating other than 200% of continuous current rating.
4. Delayed time-current curve; B, C, D, or E.
5. Number of operations on delayed curve: 0, 1, 2, 3, or 4.
6. Closing solenoid voltage code.

**Table 17. Closing Solenoid Voltage Code Numbers**

Phase-to-Phase Closing Solenoid Operating Voltage $\pm$ 15% (kV)	Code No.
2.4	1
3.3	10
4.16-4.8	2
6.0	6
7.2-8.32	3
11.0	9
12.0-13.2	4
14.4	5
17.0	12
20.0	11
23.0-24.9	13
34.5	14
Low-Voltage Closing Solenoid Operating Voltage (Vdc)	
48	16*
125	7*
250	8*

\* Requires either low-voltage DC closing accessory (KA631R) or low-voltage AC closing accessory (KA742R). Order separately.



**Table 18. Multi-Ratio Bushing Current Sensing Transformers Factory-Installed on Load-Side Bushings 2, 4, and 6\***

Description	Catalog Number**
Types W and VW	
Three 600:5 BCTs on 13 in. creepage bushings	KA804W3X
Three 600:5 BCTs on 17 in. creepage bushings	KA110W3X***
Three 1200:5 BCTs on 13 in. creepage bushings	KA827W3X
Types WV27 and VVV27	
Three 600:5 BCTs on 26-1/2 in. creepage bushings	KA14WV3X
Three 1200:5 BCTs 26-1/2 in. creepage bushings	KA24WV3X
Types WV38X and VVV38X	
Three 600:5 BCTs on 26-1/2 in. creepage bushings	KA82WV3X
Three 1200:5 BCTs on 26-1/2 in. creepage bushings	KA83WV3X

\* To specify accessory BCTs on source-side bushings, include the digit "9" after the "A" in the catalog number and specify source-side bushings in the order description.

\*\* If factory wiring is ordered, replace the "X" in the catalog number with the ratio to be connected: 1200 = 1200:5; 1000 = 1000:5; 900 = 900:5; 800 = 800:5; 600 = 600:5; 500 = 500:5; 450 = 450:5; 400 = 400:5; 300 = 300:5; 250 = 250:5; 200 = 200:5; 150 = 150:5; 100 = 100:5; 50 = 50:5.

\*\*\*Catalog number includes the extra-creepage bushings.

**Table 19. 600:5 Multi-Ratio Bushing Current Transformers for Field Installation**

Description	Catalog Number
Slip-on bushings current transformer kit; one BCT per kit	KA712L2
Set of 3 BCTs	KA712L2-3
Wiring kit for KA712L2-3 (one wiring kit required per recloser) Basic cable, no length. Replace X with number of feet.	KA895R7-X

**Table 20. Service-Related; Hardware**

Description	Catalog Number
Junction box with terminal block; factory-installed	KA187R
Manual closing tool; de-energized recloser, factory-installed W, VW, WV27, and VVV27 WV38X, VVV38X	KA476R KA66WV
T-handle closing tool: de-energized recloser	KA90R2
Oil-level sight gauge; factory-installed	KA161W

**Table 21. Automatic Tripping and Closing; Factory-Installed**

Description	Catalog Number
Hydraulic ground trip*	KA510R2XXX**
Electronic ground trip; minimum-trip current and timing curves must be specified*** Types W and WV27 Types VW and VVW27 Types W and WV27 with KA742, AC closing Types VW and VVW27 with KA742, AC closing Type WV38X Type VVW38X Type WV38X with KA742, AC closing Type VVW38X with KA742, AC closing	KA1219R1 KA1219R2 KA1219R3 KA1219R4 KA62WV1 KA62WV2 KA62WV3 KA62WV4
Specify minimum-trip resistor Select minimum-trip current of 5, 10, 20, 30, 50, 70, 100, 140, 200, 280, 320, or 400 A Minimum-trip resistor____amperes.	KA1197R____****
Specify constant time plug in first socket Select timing plug 1, 2, 3, 4, 5, 6, 7, 8, or 9 Timing plug_____	KA1199R__-1__†
Specify constant time plug in second socket Select timing plug 1, 2, 3, 4, 5, 6, 7, 8, or 9 Timing Plug_____	KA1199R__-2__†
-OR-	
Specify inverse time plug in first socket Select timing plug 1, 2, 3, 4, 5, or 6 Timing plug_____	KA1200R__-1__†
Specify inverse time plug in second socket Select timing plug 1, 2, 3, 4, 5, or 6 Timing plug_____	KA1200R__-2__†
Ground-trip blocking switch for KA510R, KA1219R, and KA62WV With manual switch handle. (Not mounted or wired. Generally used when recloser is mounted in KA89WV1 frame and switch is to be mounted on frame. Also for mounting remote from recloser.)	KA813R1††
With pulling for hotstick (Mounted on recloser and wired to junction box. Cannot be used if recloser is mounted in KA89WV1 frame or in KA146W5 frame that has a KA146W2 windlass.)	KA813R2††
With pulling for hotstick; for use when recloser is mounted in KA89WV1 frame or in KA146W5 frame that has a KA146W2 windlass. (Mounted on recloser and wired to junction box.)	KA813R4†††
Dual reclosing time First reclosing: 30 cycles First reclosing: 45 cycles	KA547R1 KA547R2

- \* Requires KA187R junction box with terminal block, multi-ratio BCT accessory as shown in Table 3 and a KA843R, factory wiring, or KA850R, factory assembly, to complete wiring from multi-ratio BCTs to the ground trip mechanism. Hydraulic ground trip accessory cannot be used on a recloser that has a KA378R remote trip.
- \*\* Replace "Xs" in catalog number in following sequence from left to right: number of time-delay curve desired; number of fast operations (0, 1, 2, 3, or 4); and the numeral "1" for series-connected or the numeral "2" for parallel-connected coils.
- \*\*\* **Note:** Electronic ground trip accessory cannot be used on a recloser that has KA378R remote trip, KA631R DC closing, KA275R or KA276R remote block of closing, or KA1169R closing coil transfer switch.
- \*\*\*\* Complete the catalog number by specifying the selected value of the component.
- † Complete the catalog number by specifying the selected value for the component and the number of operations.
- †† Requires KA187R junction box with terminal block.
- ††† Junction box is included with accessory; do not order separately.

**Table 22. Remote Operation and Indication; Factory-Installed**

Description	Catalog Number
Three-stage auxiliary switch with six independent contacts	KA369R3
Lockout-indicating switch; dpdt contacts operated by recloser operating handle	KA296R1
Remote trip 120 Vac 240 Vac 24 Vdc 48 Vdc 125 Vdc	KA378R1* KA378R2* KA378R5* KA378R4* KA378R3*
Remote lockout 120 Vac 240 Vac 24 Vdc 48 Vdc 125 Vdc	KA475R1** KA475R2** KA475R3** KA475R4** KA475R5**
Remote close 120 Vac 240 Vac 48 Vdc 125 Vdc	KA486R1† KA486R2† KA486R4† KA486R3†
Remote block of closing with coil de-energized 120 Vac 240 Vac or 125 Vdc	KA275R1*** KA275R2***
Remote block of closing with coil energized 120 Vac 240 Vac or 125 Vdc	KA276R1*** KA276R2***

\* Requires KA187R junction box with terminal block. Remote trip cannot be used on a recloser that has KA510R, KA62WV, or KA1219R ground trip accessories.

\*\* Requires KA187R junction box with terminal block.

\*\*\* Requires KA187R junction box with terminal block. Remote block of closing accessories cannot be used on a recloser that has a KA1219R or KA62WV electronic ground trip.

† Can not be used on WV38X and VVV38X.

**Table 23. Low-Voltage Closing; Factory-installed**

Description	Catalog Number
Low-voltage DC closing, requires that recloser be ordered with DC closing coil 48 Vdc Types W, WV27, WV38X Types VW, VVV27, VVV38X	KA631R11* KA631R13*
125 Vdc Types W, WV27, WV38X Types VW, VVV27, VVV38X	KA631R1* KA631R5*
250 Vdc Types W, WV27, WV38X Types VW, VVV27, VVV38X	KA631R2* KA631R6*
Low-voltage AC closing; with KA1219 or KA62WV, electronic ground trip; requires that recloser be ordered with DC closing coil 120 Vac Types W, WV27, WV38X Types VW, VVV27, VVV38X	KA742R22** KA742R24**
240 Vac Types W, WV27, WV38X Types VW, VVV27, VVV38X	KA742R23 KA742R25
Low-voltage AC closing, without electronic ground trip, requires that recloser be ordered with DC closing coil 120 Vac Types W, WV27, WV38X Types VW, VVV27, VVV38X	KA742R1** KA742R5**
240 Vac Types W, WV27, WV38X Types VW, VVV27, VVV38X	KA742R2** KA742R6**

\* Requires KA187R junction box with terminal block. Dc closing accessory cannot be used on a recloser that has a KA1219R or KA62WV ground trip.

\*\* Requires KA187R junction box with terminal block.

Effective January 2016

**Table 24. Bushings and Terminals; Factory-Installed (set of six)**

Description	Catalog Number
17-in. creepage standard length bushings Types W and VW	KA25W
Flat-pad terminals, two-hole Types W, VW with 13 in. or 17 in. creepage, standard or CT length bushings Types WV27, WV38X, VVW27, VVW38X with 261/2 in. creepage, standard length bushings Types WV27, WV38X, VVW27, VVW38X with 261/2 in. creepage, CT length bushings	KA82W1 KA62RV3 KA62RV4
Flat-pad terminals, four-hole Types W, VW with 13 in. or 17 in. creepage, standard or CT length bushings Types WV27 and VVW27 with 261/2 in. creepage, standard length bushings Types WV27 and VVW27 with 261/2 in. creepage, CT length bushings	KA156W1 KA61RV3 KA61RV4
Stud terminals, 11/8 12 UNF-2A Types W, VW with 13 in. or 17 in. creepage, standard or CT length bushings Types WV27, WV38X, VVW27, VVW38X with 261/2 in. creepage, standard length bushings Types WV27, WV38X, VVW27, VVW38X with 261/2 in. creepage, CT length bushings	KA800W1 KA59RV3 KA59RV4

**Table 25. Epoxy Bushings (set of six) and Required Terminals**

Description	Catalog Number
Epoxy bushing, standard length Types WV27, WV38X, VVW27, VVW38X	KA67RV3
Epoxy bushing, BCT length Types WV27, WV38X, VVW27, VVW38X	KA67RV4
Eyebolt terminals, 1/0 to 500 MCM cable Types WV27, WV38X, VVW27, VVW38X	KA68RV2
Flat-pad terminals, two-hole Types WV27, WV38X, VVW27, VVW38X	KA68RV3
Stud terminals, 1 1/8-12 UNF2 Types WV27, WV38X, VVW27, VVW38X	KA68RV4
Flat-pad terminals, four-hole Types WV27	KA81RV5*
Flat-pad terminals, four-hole Types WV38X, VVW27, VVW38X	KA81RV7*

\* Limited to 125 kV BIL.

**Table 26. Factory Assembly of Recloser and Accessories in KA89WV1 Substation-Mounting Frame\***

Description	Catalog Number
Recloser on frame; no accessories with or without BCTs	KA813W
Factory assembly with ground trip and shorting switch	KA850R

\* Includes factory assembly only; recloser, accessories, and mounting frame must be ordered separately.

**Table 27. Factory Assembly of Recloser in Pole-Mounting Frames\***

Description	Catalog Number
Recloser in KA146W5; with or without BCTs	KA881R2
Recloser in KA706R1; with or without BCTs	KA881R1

\* Includes factory assembling only; recloser and mounting must be specified separately.

**Table 28. Mounting Equipment**

<b>Description</b>	<b>Catalog Number</b>
Substation-mounting equipment	
Basic mounting frame	KA89WV1
Hardware for attaching KA813R ground-trip blocking switch to KA89WV1 frame	KA89WV6
Removable tank-lifting windlass for KA89WV1 frame	KA89WV2
Pole-mounting equipment	
Single-pole-mounting hanger	KA146W5*
End-mounted pole hanger	KA706R3
Tank-lifting windlass for single-pole hanger	KA146W2
Surge-arrester-mounting bracket	
Inboard (source)	KA126H3
Outboard (load)	KA847W

\* Requires KA883R, BCT conduit assembly, when recloser has source-side BCTs.

**Table 29. Factory Assembly of Conduit and Wiring\***

<b>Description</b>	<b>Catalog Number</b>
BCTs wired to KA510R2 hydraulic ground trip through KA187R junction box.	
If recloser is to be mounted with a KA146W5 frame and BCTs are on the pole side, a KA883R2 conduit kit must be specified	
Types W, VW, WV27, VVV27	KA843R
Types WV38X, VVV38X	KA80WV

\* Includes factory assembling only; recloser, accessories, and mounting must be specified separately.

**Table 30. Training-Related; Equipment Maintenance and Operation Aids**

<b>Description</b>	<b>Catalog Number</b>
General Maintenance and Inspection Procedures for Reclosers DVD (28 min.)	KSPV1A
Mechanical Operation, Service and Testing for Three-Phase Hydraulic Reclosers DVD (28 min.)	KSPV5A

This page is intentionally left blank.

This page is intentionally left blank.

**Eaton**  
1000 Eaton Boulevard  
Cleveland, OH 44122  
United States  
Eaton.com

**Eaton's Cooper Power Systems Division**  
2300 Badger Drive  
Waukesha, WI 53188  
United States  
Eaton.com/cooperpowerseries

© 2016 Eaton  
All Rights Reserved  
Printed in USA  
Publication No. CA280005EN

Eaton is a registered trademark.  
All other trademarks are property  
of their respective owners.

For Eaton's Cooper Power series product  
information call 1-877-277-4636 or visit:  
[www.eaton.com/cooperpowerseries](http://www.eaton.com/cooperpowerseries).